

SSEN Distribution

YOUR CUSTOMER SERVICE GUIDE



POWER CUT?

In the event of a power cut, call our 24/7 contact centre.

Just dial 105 to be connected to our team.

**POWER CUT?
CALL 105**



Scottish & Southern
Electricity Networks

Powering our
community



ABOUT THIS GUIDE

This guide will provide you with the following information:

About us	3
Power cuts and how to prepare for them	4
Power cuts - Be Prepared in advance	5
Priority Services Register (PSR)	6
Fuel Poverty referral information	7
Visiting your home	8
Complaints	9
Our Complaints process	10
Guaranteed Standards	11
Contact us	12

PAGE

GUIDE SUPPORT

If you need this document, in a different format such as:

- Translated into an alternative language
- Easy Read format
- Large print
- Hard copy
- Audio CD
- Braille

Please contact our Priority Services Team.



Call our Priority Services Team

0800 294 3259

Or email us via:

networks.priority.services@sse.com

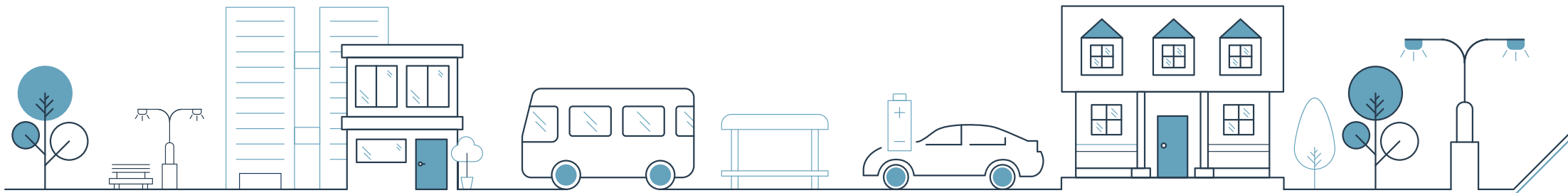



ABOUT US

We are Scottish and Southern Electricity Networks.

It's our responsibility to manage, maintain and develop the electricity networks which bring power to over 3.9 million homes and businesses in the north of Scotland and central southern England.

It's important to be aware that we are not an energy supplier (the company you pay your electricity bill to).

Our priority is to provide a safe and reliable supply of electricity to the communities we serve in Scotland and England.



Over 3.9 million homes and businesses served by our networks



More than 822,000 customers on our Priority Services Register



Over 127,000km of overhead lines and underground cables

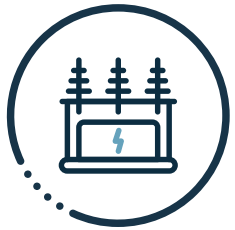

115,000 substations



460km subsea cables powering island communities



Over 4,000 employees across the country

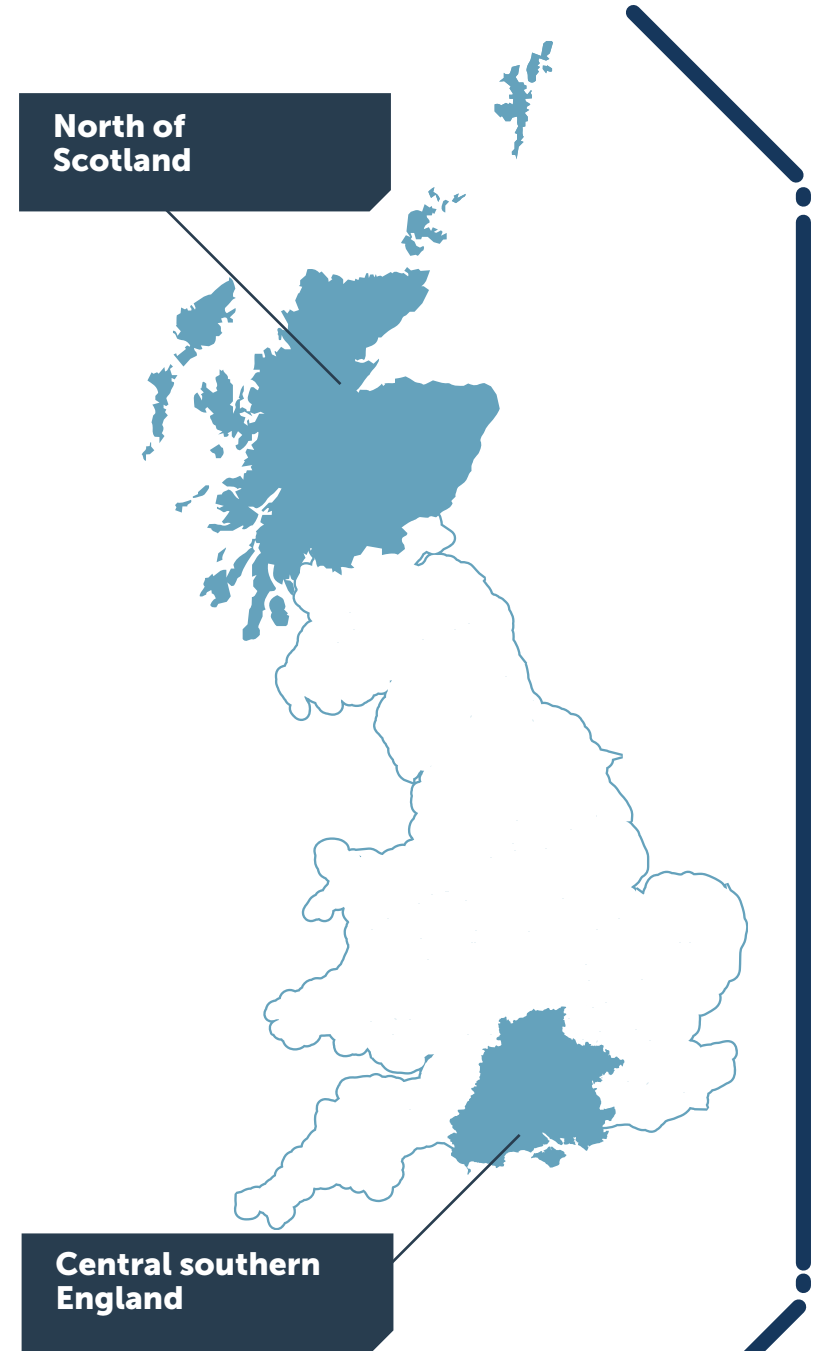



POWER CUTS AND HOW TO PREPARE FOR THEM

Keeping your power on safely is our number one priority, and we invest millions every year to upgrade and strengthen our network, however, even with this investment and maintenance, unfortunately there are times when power cuts occur.

On other occasions, we may need to turn your power off for a short time to carry out essential maintenance; when this is the case, we will aim to provide you with 30 days' notice if you are a business customer and 7 days' notice if you are a domestic customer, where possible.

We will follow this up with a reminder message the day before if we have your telephone number. If for any reason the timescales we have provided you with for a planned outage are not met, we will aim to contact you.

Furthermore, if you are registered on our Priority Services Register, we will aim to call you to ensure you are supported during power cuts.

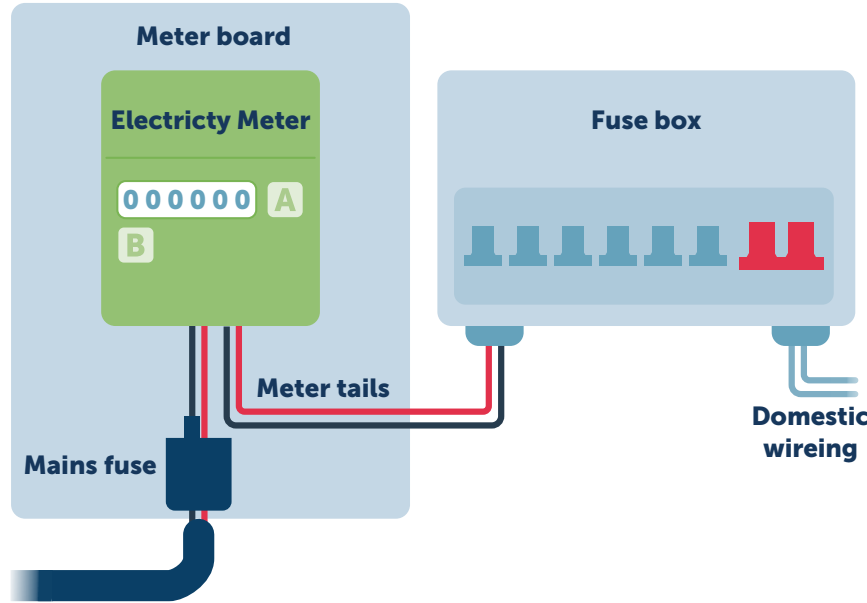

Main distribution cable

RESPONSIBILITY - COLOUR KEY

- Homeowner / Landlord**
A qualified electrician can support you with this and any internal wiring
- Electricity Supplier**
This is maintained by your electricity supplier
- SSEN Distribution**
Equipment provided by your distribution network operator (dno)

For illustration purposes, meters, cables and colours will vary

Main distribution cable
The cable that we maintain to your property, which brings the your electricity from the grid.
Referred as: distribution cable, mains cable

Mains fuse
We install the cutout with main fuse, which protects your property in the event of a power surge.
Referred as: cutout, main fuse

Meter tails
These are the cables between the meter and your consumer unit.
Referred as: meter cables

Electricity Meter
This is either a smart meter or standard meter. This is provided by your electricity supplier. They are the company who sends your electricity bills.
Referred as: supply meter

Fuse box
This is an important electrical device, it protects electrical appliances from damage and you from electrical shock.
Referred as: consumer unit, fuse box, fuse panel

Meter board
This is a wooden board which your supply meter is mounted to and is screwed to the wall.





POWER CUTS - BE PREPARED IN ADVANCE

Whether you have to stay in or get out, packing a small emergency kit will help you get through. Keep it in a safe place at home where you can reach it easily. Your kit should be kept in a waterproof bag if possible, and the top recommended items to include are:

Things to consider



If you rely on medical equipment/aids reliant on electricity, check to see if it can work with a battery or if it can operate manually. If not, have a plan in place so that you know what to do in the event of a power cut.



If you rely on oxygen, ensure that you have back up cylinders and you have the number for your healthcare professional or oxygen supplier handy to call if you need more.



Traditional style telephones that plug directly into the telephone socket in the wall will work during a power cut.



Switch off appliances and lights but leave one light on. So you know when power has been restored.



Don't open the freezer door unless you have to. This helps food stay frozen for longer. When the power comes back on, check the food inside. Food should keep for about 8-12 hours without power. Always check your manufacturer's manual to make sure.



If you have elderly or vulnerable neighbours, check to make sure they are comfortable.



If we have warned you in advance that the electricity will be turned off, boil some water and keep it in a insulated flask.

Be Prepared - Pack an Emergency Kit



Essential

- Bottled water and non-perishable foods** (inc. Baby food/pet food)
- First aid kit** (and essential medicines)
- Radio and Torch** (spare batteries or wind-up equivalent)
- Identity documents** (passports/drivers licence)
- Change of clothes** (inc. warm jumpers and blankets)
- Mobile phone charger** (ideally a portable charger)

In addition

- Money (change, cash and card)**
- Spare keys for house and car**
- Copies of insurance policies and birth certificates**
- Spare glasses/contact lenses**
- Notebook, pen/pencil**



PRIORITY SERVICES REGISTER

We know that a power cut can be worrying or difficult, that's why we offer free extra help and support. We can help you far better, and quicker, if we know in advance what extra support you might need.

You can sign up if you



Are dependent on electricity for home medical care



Have a chronic illness or short term medical condition



Are disabled



Have special communication needs



Are blind or partially sighted



Deaf or hard of hearing



Have children under 5



Are over 60 years old



Require assistance for another reason, even if temporarily

Of course, everyone has different needs so feel free to contact us to discuss your requirements.

What our Priority Services offers you

- ✓ During severe weather events and prolonged power outages, we will do everything we can to keep you informed about when supply is likely to be restored and what help we may be able to provide. You will receive regular power cut updates 24 hours a day.
- ✓ Our Priority Services line is available 24 hours a day. We'll contact you, or your nominated contact, if we need to switch off your power to carry out essential maintenance.
- ✓ When requested, we'll offer you advice on how to prepare for a power cut in a format that suits your needs, e.g. Braille, textphone, audio CD, Easy Read or in another language.
- ✓ We work with local authorities, emergency services and agencies, like British Red Cross, to provide extra support to people on our Priority Services Register.
- ✓ During severe weather events and prolonged power outages, we will do everything we can to keep you informed about when supply is likely to be restored and what help we may be able to provide.
- ✓ Our connection to local welfare vehicles help us in our aim to provide meals, drinks, warmth and charging points for those who need them.
- ✓ We offer a service where you can agree a password to use when dealing with SSEN staff. That way we can look after your personal safety and home security.
- ✓ You can nominate a friend or family member that we can contact regarding Priority Services and power disruptions on your behalf.
- ✓ Energy Suppliers also offer Priority Services. If you register with us, and if you consent, we will pass your details to your energy supplier for you.

Contact our Priority Services team today



Priority Services web page
ssen.co.uk/psr



Priority Services Email
networks.priority.services@sse.com



Priority Services helpline
0800 294 3259



ENERGY EFFICIENCY HELP

We have partnered with Home Energy Scotland (HES) and Yes Energy Solutions (YES) to help you stay warm for less.

We can arrange free expert advice for you on:

- Saving energy and reducing bills
- Funding or grants to pay for insulation or energy saving measures
- Financial help
- Making the most of your heating, hot water, appliances, lighting and thermostats in your home
- Keeping warm without spending more
- Benefit entitlement checks



Fuel Poverty referral support

Call us free or you can complete our online form here



Fuel Poverty Advice
0800 294 3259



Online Help and Advice
ssen.co.uk/energy-advice



Did you know?

Many people miss out on money that's there to help, such as the Warm Home Discount, Winter Fuel Payment and the Cold Weather Payment.



VISITING YOUR HOME

Our teams work directly with communities, helping customers on the phone or occasionally visiting you in your home. It is important that you feel safe in your home and have confidence that our staff are skilled and trustworthy.

Our Standards for visiting your home

We want our customers to know that our staff are “Fit and Proper” and have a minimum set of standards that define this.

All our employees and contract partners will:

- Show their identity cards on arrival and always explain the reason for their visit
- Be clean, tidy, polite and respectful
- Have relevant checks done to ensure they act with integrity and honesty
- Have understanding of customer processes and policies, including identifying and supporting customers in vulnerable situations
- Be able to communicate professionally and clearly with customers/stakeholders at all levels in a variety of situations, including in customers homes, schools and pre-arranged events
- Use social media professionally and in line with our internal processes and policies
- Have the competence, skills and experience necessary for their role

Set up a password for peace of mind

To provide you with extra reassurance that any visits from our staff are genuine, you can set up a password in advance at any time. Then whenever we visit, whether or not we have been able to arrange an appointment, our employees will use the password.

Our employees can also provide you with contact details for help and advice on the safety and security of your electrical supply if they are not able to answer any enquiry themselves.

We may use contractors to carry out work, if this is the case we expect them to work using the same procedures, principles and ethics maintained by SSEN employees.

If you are unsure that a caller is genuine, do not let them into your home. If you are in doubt call us on



Call to ID Check
0800 015 5170



To set up a password please contact us



Set up a password
0800 048 3516



COMPLAINTS

All our staff are highly trained to offer you the best possible customer service and will do their utmost to help you. If they need to involve their manager, they will do so to ensure the matter is resolved as quickly and easily as possible.

How to raise a complaint

We've made it as easy as possible for you to contact us with a complaint.

- 1 Contact us**
We need to know how we can help you, you can reach us by phone, email or via our web form.
- 2 We will help**
We will attempt to resolve your complaint within the initial call or we will follow the Ofgem approved industry standard complaints process (please see page 10).
- 3 If you need further support**
If we cannot find a solution or resolve your complaint we will provide guidance to what you can do next.

Citizens Advice

The Citizens Advice consumer service advisers offer independent, impartial advice. If you are a domestic customer, you can contact them at any point regarding your complaint.

POWER CUT?

In the event of a power cut, call our 24/7 contact centre.

Just dial 105 to be connected to our team.

**POWER CUT?
CALL 105**



Our contact details

-  Call our complaints team
0800 980 1395
-  Online complaints form
[ssen.co.uk/complaints](https://www.ssen.co.uk/complaints)
-  Email our complaints team
customercomplaints@ssen.co.uk

Full contact details are available on our Contact page (please see page 10).

Citizens Advice contact details

-  Citizens Advice website
[citizensadvice.org.uk](https://www.citizensadvice.org.uk)
-  Citizens Advice helpline
03454 040 506



OUR COMPLAINTS PROCESS

We will log your complaint and attempt to resolve matters for you as quickly as possible. Our complaints process is explained below:

SSEN DISTRIBUTION COMPLAINT PROCESS

Day 1

INITIAL FIRST CONTACT

You can raise a complaint with us by phone, email, post or even online and a member of our dedicated complaints team will be happy to help.

When you call us with a problem, our staff will attempt to resolve matters there and then. If you email or write to us, we aim to resolve matters within 2 working days. We may call you to do this.

Day 4

SSEN COMPLAINTS TEAM

If you're still unhappy after our initial contact with you, we'll spend the first 4 days trying to find a resolution for you.

During this time the Head of Region for your area will be involved every day and an independent reviewer will ensure all options have been considered to resolve your complaint as quickly and effectively as possible.

Day 4 - 31

EXECUTIVE COMPLAINTS TEAM

If the complaint is still unresolved after 4 days, we will pass the complaint to our Executive Complaints Team.

Our Executive Complaints Team are a specialist team who will spend time to look into your complaint and see if there's something they can do to help find a resolution.

8 Weeks

INDEPENDENT REVIEW/ MUTUAL RESOLUTION

If your complaint reaches 8 weeks (or 56 days), it will automatically be independently reviewed. When your complaint reaches this stage, you have the right to approach the 'Ombudsman Services: Energy', for further guidance and they will review your case.

During this time, we will continue to work with you to reach mutual resolution however if we are unable to resolve your complaint to your satisfaction, a final offer or deadlock letter will be sent and you can again approach 'Ombudsman Services: Energy', to have your case reviewed by them. 'Ombudsman Services: Energy' are there to resolve disputes between consumers and companies, there service is free and impartial.

Day 31+

SENIOR MANAGER REVIEW

If after 31 days, you're still unhappy with what we've done, a senior manager or Head of Business Area will take on your complaint to investigate.

The senior manager or Head of Business Area will work with you to find a suitable resolution and if you're still unhappy, will discuss the next steps for you. This is the final internal stage of our Complaints Handling Process.

Key



You/our customer



Us/SSEN Distribution

All time scales are expected to be discussed and agreed with customers and therefore may vary depending on circumstances.



SAFETY AND SECURITY OF SUPPLIES

Our priority is to provide you with a constant, reliable supply of electricity. Sometimes things like severe weather can impact the your electricity supply but be assured that we'll always work as quickly as possible to restore your power.

Safety and Security of Supplies

If you have any questions regarding the maintenance of the security, availability or quality of service of the electricity network or would like to report anything in relation to the electricity network that you feel we should be aware of or could be unsafe, please contact us. For Example, you could contact us if you have problems with your power supply, such as flickering lights, or if you see damage to an electricity overhead cable or substation.

You can keep track of your local supply status here:

[ssen.co.uk/powertrack](https://www.ssen.co.uk/powertrack)

or you can download our free Power Track app which allows you to easily report a problem with your power and report damage to our network. All reports of damage or power cuts are processed in a prompt and efficient manner.

Performance Standards

Our industry has Guaranteed Standards of Performance for restoring power and providing other services, such as keeping appointments.

If we don't meet any of these standards, we are required to pay our customers compensation. For example, if your electricity supply fails because of a problem in our network during normal weather conditions, we must restore it within 12 hours of first becoming aware of the problem. If we are unable to restore it in this time, we will make payments within our Guaranteed Standards of Performance guidelines. Other standards apply in more extreme weather events or circumstances.

The Guaranteed Standards specify exactly who is entitled to receive compensation and how much this compensation will be. You can find a copy of the Guaranteed Standards at

[ssen.co.uk/about-ssen/performance-standards](https://www.ssen.co.uk/about-ssen/performance-standards)

Your Data

SSEN need to know your basic personal data to be able to maintain and operate the electricity transmission and distribution networks for which we are responsible.

We may also have your sensitive personal data if you have consented to be on our Priority Services Register.

In particular, we need to know your basic personal data to direct your enquiries to the correct SSEN team, to allow our engineers to visit you onsite where required and to provide assistance to you in the case of an emergency.

To learn more about how we manage your data you can read our privacy notice **[ssen.co.uk/privacynotice](https://www.ssen.co.uk/privacynotice)**

CONTACT US

POWER CUT?

Call the short dial power cut number

 **CALL 105**

Our power track website and app

 Report and track a fault
powertrack.ssen.co.uk

PRIORITY SERVICES

 Priority Services direct
0800 294 3259

 Priority Services Text phone
0800 316 5457

 Priority Services Email
networks.priority.services@sse.com

 Priority Services web page
ssen.co.uk/psr

 BSL InterpreterNow
interpreternow.co.uk/ssen

COMPLAINTS

 Call our complaints team
0800 980 1395

 Online complaints form
ssen.co.uk/complaints

 Email our complaints team
customercomplaints@ssen.co.uk

OUR ADDRESS

 **North of Scotland office**

Complaints Manager
Scottish and Southern Electricity Networks
Inveralmond House, 200 Dunkeld Road
Perth
PH1 3AQ

 **Central Southern England Office**

Complaints Manager
Scottish and Southern Electricity Networks
Walton Park, Walton Road
Portsmouth
PO6 1UJ

WEB AND SOCIAL MEDIA

 Our main website
ssen.co.uk

 Twitter
@ssencommunity

 Facebook
/ssencommunity

 Whatsapp
0734 202 8546